

Surface Infrared Studies of Silicon/Silicon Oxide Interfaces Derived from Hydridosilsesquioxane Clusters

J. N. Greeley, L. M. Meeuwenberg, and M. M. Banaszak Holl*

Contribution from the Department of Chemistry, The University of Michigan, Ann Arbor, Michigan 48109-1055

Received March 5, 1998

Abstract: Hydridosilsesquioxane-based model systems have been developed over the past five years to help elucidate the structure and reactivity properties of silicon/silicon oxide interfaces. In this paper, the assignment of infrared bands as Si–O or Si–H derived is explored via deuterium labeling studies. In particular, the issue of the presence of adventitious water in the model interfaces is directly addressed via the chemisorption of deuterated-spherosiloxane clusters ($D_8Si_8O_{12}$) onto clean Si(100). The experiments definitively demonstrate that there are no water-derived features detectable by RAIRS in the model interfaces. This rules out water contamination as a possible explanation for the 1.0 eV shifted feature observed in Si 2p core-level spectroscopy for the model systems. This work is further supported by cluster and water co-dosing experiments on Si(100), which address the spectroscopic sensitivity of surface silicon–hydrides in this system. Finally, the first surface crystallographic studies of the model interfaces performed with LEED are presented. The chemisorbed hydridosilsesquioxane model systems are shown to retain the 2×1 reconstruction of the original Si(100) surface.

I. Introduction

The Si/SiO₂ interface is ubiquitous throughout the microelectronics industry.¹ As circuit dimensions shrink to the molecular level, understanding the structure and reactivity of this interface is of the utmost importance. To help realize this goal, we have developed a program that spectroscopically studies model silicon/silicon oxide systems. The intention of this program is to spectroscopically characterize structural moieties in simpler model systems, and then apply this knowledge to garner a greater understanding of the interface in actual metal oxide semiconductor field effect transistors (MOSFET). To date, five different silicon/silicon oxide model interfaces have been synthesized, via exposure of spherosiloxane clusters ($HSiO_{1.5}$)_n ($n = 8, 10, 12, 14$) to Si(100)- 2×1 , and characterized with use of soft X-ray photoemission spectroscopy.² A Si 2p core-level spectrum of the interface derived from the reaction between $H_8Si_8O_{12}$ and Si(100)- 2×1 is shown in Figure 1 along with the structural assignments made for the observed core-level peaks. This paper addresses a number of key issues regarding the infrared spectroscopy of the model interface structures. First, the origin of the observed infrared bands as Si–O or Si–H derived was probed with deuterium labeling experiments. The issue of adventitious water and the extent to which it is present in the model interfaces is addressed. Second, the spectroscopic sensitivity of these experiments to surface silicon–hydrides is quantified for this system. Third, the results of Low-Energy Electron Diffraction (LEED) studies of the $H_8Si_8O_{12}$ derived model interface, the first surface crystallographic study of these systems, are presented. The results from these experiments are then placed into the context of previous soft X-ray photoemission experiments on these model systems.²

(1) For examples see: *The Physics and Chemistry of SiO₂ and the Si–SiO₂ Interface-3*; Massoud, H. Z., Poindexter, E. H., Helms, C. R., Eds.; The Electrochemical Society, Inc.: Pennington, NJ, 1996; and references therein.

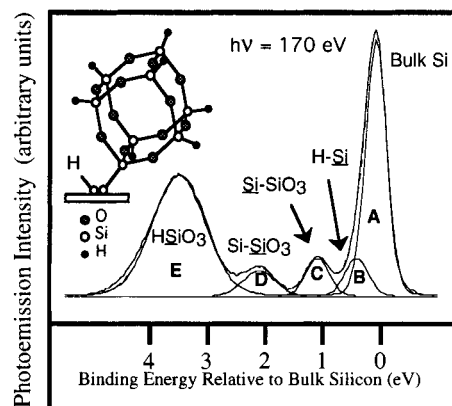

Figure 1. Si 2p core-level spectrum of the model interface derived from $H_8Si_8O_{12}$ on Si(100)- 2×1 and a schematic picture of the proposed interface structure.

The first reflection–absorption infrared spectroscopy (RAIRS) experiments on this class of clusters, $H_8Si_8O_{12}$ adsorbed on Si(100)- 2×1 , were carried out by Eng *et al.*³ Comparison of their surface IR spectra data to that obtained by Calzaferri *et al.* for $C_6H_{13}(H_7Si_8O_{12})$ in CCl_4 showed many structural similarities.⁴ Most interestingly, in both cases it was argued that the O_h symmetry of the free $H_8Si_8O_{12}$ cluster was lowered to C_{3v} via substitution at the cluster vertex, splitting the triply degenerate $\delta(H-SiO_3)$ mode. Eng *et al.* concluded that the observed spectrum was consistent with the structure previously assigned by X-ray photoemission spectroscopy (XPS), namely, a cluster bound to the silicon surface at a single vertex (as shown schematically in Figure 1). The assignment of vibrational

(2) (a) Banaszak Holl, M. M.; McFeely, F. R. *Phys. Rev. Lett.* **1993**, *71*, 2441. (b) Lee, S.; Mekan, S.; Banaszak Holl, M. M.; McFeely, F. R. *J. Am. Chem. Soc.* **1994**, *116*, 11819. (c) Zhang, K. Z.; Meeuwenberg, L. M.; Banaszak Holl, M. M.; McFeely, F. R. *Jpn. J. Appl. Phys.* **1997**, *36*, 1622. (d) Zhang, K. Z.; Banaszak Holl, M. M.; Bender, J. B.; Lee, S.; McFeely, F. R. *Phys. Rev. B* **1996**, *54*, 7686.

features was supported by density-functional calculations. They also concluded that a small amount of water was present on the surface based upon the assignment of an IR peak observed at $\sim 820\text{ cm}^{-1}$. This is the location of the $\nu(\text{HO}-\text{Si})$ mode absorption frequency for a water-treated Si(100) surface.⁵ Moreover, no cluster related IR peaks in this region were observed in their calculations for a C_{3v} symmetric cluster.³ Although they estimated that the total amount of water contamination was low, possible screening of the water features by the bound clusters made it impossible to be certain of the exact ratio of water to cluster present.

This issue is of crucial importance because water contamination has been proposed as a possible explanation for peak C in Figure 1. The observed binding energy shift of 1.0 eV for the Si 2p core-level is identical to that observed for a Si₃SiOH group on a Si(100)-2 \times 1 surface. The assignment of this photoemission feature as a Si₃SiSiO₃ fragment, with a 1.0 eV BE shift caused by the second neighbor coordination sphere, has been controversial and it is critical to conclusively address the issues of model structure and possible contamination.⁶ Spectroscopic assignment of silicon/silicon oxide interfaces in the literature has been based upon a Formal Oxidation State (FOS) assignment scheme that focuses on the first neighbor coordination shell.^{1,7,8} However, XPS studies of the hydridosilsequioxane-based models provide data that contradict the previous assumptions and in fact support an assignment scheme that incorporates second-neighbor effects, as is generally accepted for gas-phase XPS studies.⁹ These key differences in assignment schemes lead to important differences in interpretation for issues such as structure, stoichiometry and reactivity (device failure) in the silicon/silicon oxide interface region for MOSFET devices.^{1,10,11} Now that the silicon oxide film used in MOSFET devices has reached the molecular scale, it is critical to have a detailed chemical understanding of this interface.

II. Experimental Section

UHV Apparatus and IR Optics. A custom-made ultrahigh vacuum (UHV) apparatus was constructed with the following capabilities: reflection-absorption infrared spectroscopy (RAIRS), low-energy electron diffraction (LEED), temperature-programmed desorption (TPD), adsorbate dosing, and sample transfer. Via a sample transfer network, it was possible to also move samples into X-ray photoemission

(3) Eng, J., Jr.; Raghavachari, K.; Struck, L. M.; Chabal, Y. J.; Bent, B. E.; Banaszak Holl, M. M.; McFeely, F. R.; Michaels, A. M.; Flynn, G. W.; Christman, S. B.; Chaban, E. E.; Williams, G. P.; Radermacher, K.; Mantl, S. *J. Chem. Phys.* **1998**, *108*, 8680.

(4) Calzaferri, G.; Imhof, R.; Tomroos, K. W. *J. Chem. Soc., Dalton Trans.* **1994**, 3123.

(5) Struck, L. M.; Eng, J., Jr.; Bent, B. E.; Flynn, Y. J.; Chabal, S. B.; Christman, S. B.; Chaban, E. E.; Raghavachari, K.; Williams, G. P.; Radermacher, K.; Mantl, S. *Surf. Sci.* **1997**, *380*, 444.

(6) McFeely, F. R.; Zhang, K. Z.; Banaszak Holl, M. M.; Lee, S.; Bender, J. E. *J. Vac. Sci. Technol. B* **1996**, *14*, 2824.

(7) (a) Himpfel, F. J.; McFeely, F. R.; Morar, J. F.; Taleb-Ibrahimi, A.; Yarmoff, J. A. in *Proceedings of the 1988 Enrico Fermi School on Photoemission and Absorption Spectroscopy of Solids and Interfaces with Synchrotron Radiation*; North-Holland: Varenna, 1988. (b) Himpfel, F. J.; McFeely, F. R.; Taleb-Ibrahimi, A.; Yarmoff, J. A. *Phys. Rev. B* **1988**, *38*, 6084.

(8) For a series of theoretical papers supporting the FOS assignment scheme see: (a) Pasquarello, A.; Hybertson, M. S.; Car, R. *Phys. Rev. B* **1996**, *53*, 10942. (b) Pasquarello, A.; Hybertson, M. S.; Car, R. *Phys. Rev. B* **1996**, *54*, R2339.

(9) (a) Zhang, K. Z.; Litz, K. E.; Banaszak Holl, M. M.; McFeely, F. R. *Appl. Phys. Lett.* **1998**, *72*, 46. (b) McFeely, F. R.; Zhang, K. Z.; Banaszak Holl, M. M. *Mater. Res. Soc. Symp. Proc.* **1997**, *446*, 15.

(10) Banaszak Holl, M. M.; Lee, S.; McFeely, F. R. *Appl. Phys. Lett.* **1994**, *65*, 1097.

(11) (a) Lee, S.; Banaszak Holl, M. M.; Hung, W. H.; McFeely, F. R. *Appl. Phys. Lett.* **1996**, *68*, 1081. (b) Zhang, K. Z.; Banaszak Holl, M. M.; McFeely, F. R. *Mater. Res. Soc. Symp. Proc.* **1997**, *446*, 241.

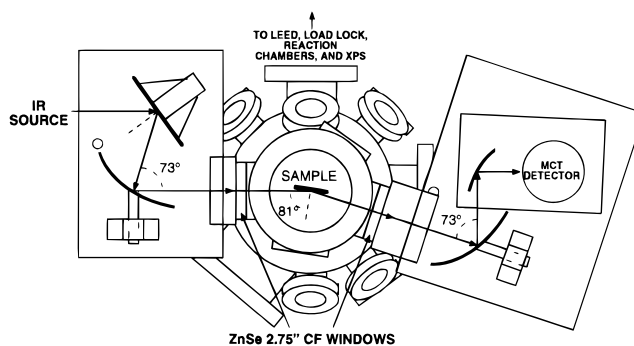

Figure 2. Experimental apparatus used to perform RAIRS. Samples can be moved to other parts of the chamber via a sample transfer system (not shown).

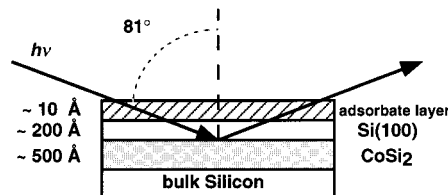

Figure 3. Cross-sectional view of the buried-metal layer (BML) Si(100) sample used for RAIRS experiments.

spectroscopy (XPS), isolatable reaction, and load-lock chambers without compromising UHV conditions.

Figure 2 illustrates the relevant features of this apparatus. The chamber has a lower level for sample transfer and TPD and an upper level for RAIRS. The remaining flanges are outfitted with standard UHV hardware, e.g., pressure gauges, viewports, and leak valves. Samples are transported between levels via a vertical manipulator (not pictured) capable of resistive heating as well as actuating the sample through polar and azimuthal angle rotations about a fixed point. Temperature was monitored via a Minolta-Land infrared pyrometer (Cyclops 52, emissivity setting of 0.7). XPS was performed with a PHI 5000C spectrometer. LEED patterns were obtained with a VG Microtech Rear View spectrometer, with an electron gun energy of 51 eV at $\sim 2\text{ \AA}$.

RAIRS was performed with a Bio-Rad FTS-40 FTIR spectrometer. The IR source beam was deflected out of the spectrometer into a N₂ purged optics box. The incident beam was focused onto the sample with a 8.5 in. focal length, 73° off-axis reflection, parabolic mirror (ORC Electroformed Products). Before impinging the sample, the IR beam passed through a 2.75 in. conflat ZnSe viewport, nominally 75% transmittant for 500–15000 cm^{-1} . In all, this optical geometry resulted in a full beam convergence of $\sim \pm 7^\circ$. The surface-scattered IR beam was collected in an analogous fashion and focused onto a liquid-N₂-cooled HgCdTe (MCT) broad-band detector with a 1.25 in. focal length, 90° off-axis reflection, parabolic mirror. As a compromise of the incident-angle dependent signal sensitivity of different materials,¹² the surface normal was rotated 81° from the incident IR beam. Elegant variable-angle IR-UHV experiments by Ogino et al. have shown the dramatic effect of incident angle on signal/noise for experiments on Si(100) BML substrates.¹³

Sample Preparation. Because silicon is highly transparent in the IR spectral region of interest, specially prepared samples (S. Mantl),¹⁴ with an internal CoSi₂ mirror, were used for these experiments. Figure 3 depicts a cross-sectional view of the buried-metal layer (BML) substrate used. Because the preparation of these samples has been discussed in detail in other places,^{3,15} we will only review the technique briefly here. In short, a Si(100) wafer was implanted with 200 keV

(12) For reviews see: (a) Hayden, B. E. In *Vibrational Spectroscopy of Molecules of Surfaces*; Yates, J. T., Madey, T. E., Eds.; Plenum: New York, 1987. (b) Chabal, Y. J. *Surf. Sci. Rep.* **1988**, *8*, 211.

(13) Kobayashi, Y.; Ogino, T. *Surf. Sci.* **1996**, *368*, 102.

(14) Samples purchased from S. Mantl, Institute für Schicht- und Ionentechnik, Forschungszentrum Jülich GmbH, P.O. Box 1913, 5170 Jülich, Germany.

Co⁺ ions, and then annealed to create a uniform buried CoSi₂ layer. The sample was then capped with a thick SiO₂ layer to protect it from contamination. This procedure creates a well-ordered Si(100)-2×1 surface on a silicon layer that is “optically thin” (i.e., thickness much less than the IR wavelength) while remaining “chemically thick” (i.e., CoSi₂ alloy not involved in chemisorption), on top of the BML.

The BML samples were prepared for UHV by the following cleaning procedure of Struck *et al.*⁵ First, samples were degreased with dichloromethane, acetone, and ethanol. This was followed by a chemical cleaning in a 75 °C solution of 1:1:4 NH₄OH:H₂O₂:H₂O for roughly 10 min. A 30 s HF rinse, used to remove the thick oxide, was followed by cycles of room temperature 1:1:4 HCl:H₂O₂:H₂O for 10–15 min and 30 s HF etching. Oxidation/etching cycling was used to remove the top 10–20 nm of the Si(100) layer; however, one cycle was usually enough to prepare a clean, well-ordered surface. Finally, a protective oxide coating was produced by placing the sample in a 75 °C solution of 1:1:4 HCl:H₂O₂:H₂O for roughly 10 min. The sample was given a final ethanol rinse, dried with N₂, put into the sample mount, and inserted into the load lock. The sample, roughly 16 mm × 10 mm, was physically separated from the stainless steel mount with Ta foil.

Once in UHV, the sample was degassed for 1 h at ~500 °C. The protective oxide was flashed off by quickly heating the sample to ~1050 °C. XPS analysis showed a clean silicon surface with no contamination, while the LEED image was a well-ordered (2×1) diffraction pattern identical to that obtained for a normal Si(100)-2×1 sample that does not contain a BML. The Si(100) surfaces were only exposed to Si, O, and H(D) so individual samples could be recleaned, *in vacuo*, numerous times before carbon contamination issues became a problem. Once a strong C 1s peak (SiC) was observed via XPS, the sample was removed. Chemical re-cleaning of contaminated samples was attempted with moderate success. All spectra presented in this paper were taken with fresh BML samples with no carbon contamination as measured by XPS. The H₈Si₈O₁₂ clusters were synthesized in our laboratory following a previously described procedure.¹⁶ D₈Si₈O₁₂ clusters were prepared by using a modification of the literature procedure.¹⁷ C₆D₆ was used as the solvent in place of pentane. This eliminates the problem of hydrogen contamination by the solvent, and generates the perdeutero cluster with >98% deuterium labeling. The H₂O and D₂O (Cambridge Isotope Laboratories) samples were degassed with multiple freeze–pump–thaw cycles.

Method. H₈Si₈O₁₂- and water-treated samples of Si(100) were synthesized by flashing the surface clean, allowing it a few minutes to cool, and then leaking in the desired gas. The base pressure of the chamber was ~5 × 10⁻¹⁰ Torr with no gas load. At this pressure, RAIRS revealed that no cluster or water adsorption on a clean Si(100) surface occurred for over 20 min, much longer than the time scale of these experiments. During dosing the pressure was typically 2 × 10⁻⁸ (H₈Si₈O₁₂) and 6 × 10⁻⁸ (H₂O and D₂O) Torr. For all experiments, the IR signal integration was performed while dosing. Separate experiments were performed to ensure that a gas-phase signal was not observed for the H₈Si₈O₁₂ cluster. All dosing was done by backfilling the chamber to the desired pressure through a sapphire leak valve, not by line-of-sight. Separate experiments have shown that these clusters can chemisorb to stainless steel;¹⁸ hence, it was necessary to “condition” the chamber with an extended cluster exposure after each bake, typically a few hours. This conditioning, however, did not affect the ultimate base pressure of the chamber. Prior to each daily experiment, the clusters were exposed to the vacuum for ~30 min to pump away any potential contaminants.

Experiments typically involved taking a background spectrum, performing the desired gas exposure, and then taking a second spectrum. The second spectrum was ratioed to the background to arrive at the final plot. Complications were introduced because of a sinusoidal feature in the baseline that increased in amplitude with time after the background spectrum was taken. Most likely, this feature is related to thermally induced changes in the optical path with time.⁵ To overcome

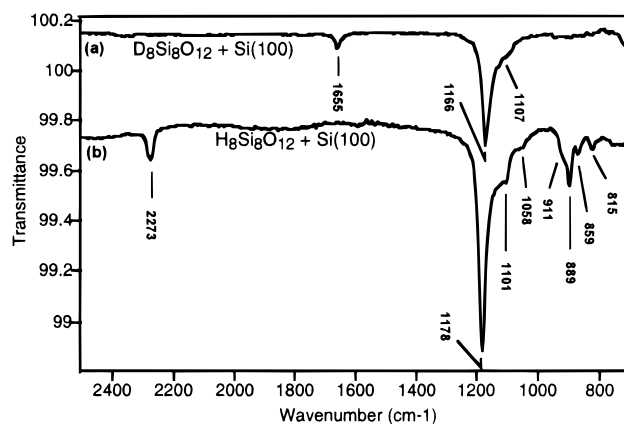

Figure 4. RAIRS spectrum of (a) D₈Si₈O₁₂ and (b) H₈Si₈O₁₂ chemisorbed on Si(100).

this problem, a compromise was made between minimizing the time between spectra and maximizing the signal-to-noise ratio. All single beam spectra represent a signal averaging of 256 scans taken with 8 cm⁻¹ resolution, where each spectrum required about 90 s to complete. Area integration and peak curve fitting was performed within the Bio-Rad software package. Normal mode calculations were performed with MacSpartanPlus from Wavefunction, Inc.

III. Results

H₈Si₈O₁₂ and D₈Si₈O₁₂ Exposure to Clean Si(100)-2×1.

The IR spectra of saturating doses of H₈Si₈O₁₂ (b) and D₈Si₈O₁₂ (a) onto clean Si(100)-2×1 are presented in Figure 4. Spectrum 4(b) shows intense features at roughly 889, 1178, and 2273 cm⁻¹ assigned as δ(H–SiO₃), ν_a(Si–O–Si), and ν(H–SiO₃), respectively. Additional peaks not observed for the free molecule are observed here at 815, 859, 911, 1058, and 1101 cm⁻¹. Detailed assignment of these peaks is discussed elsewhere;^{3,19} however, solution IR data for RH₇Si₈O₁₂ clusters shows remarkably good agreement with the 859, 911, 1058, and 1101 cm⁻¹ features.²⁰ Comparison between spectra (a) and (b) allows the origin of the observed bands to be definitively assigned as Si–O or Si–H derived. In particular, the feature at 2273 cm⁻¹ shifts to 1655 cm⁻¹, consistent with the previous assignment of this mode as ν(H–SiO₃),³ and in reasonable agreement with the shift predicted by the harmonic oscillator model. The intense ν_a–(Si–O–Si) feature at 1178 cm⁻¹, as well as the other ν_a(Si–O–Si) modes, shows a small secondary isotope shift. The modes at 911, 889, and 859 cm⁻¹, previously assigned as δ–(H–SiO₃),³ are all predicted to shift below 660 cm⁻¹ and are not observed in spectrum (a). Significantly, the mode at 815 cm⁻¹ has also shifted upon deuteration, indicating that this is also some type of Si–H derived mode. For the model structure generated from D₈Si₈O₁₂, no spectral features are observed between 700 and 1000 cm⁻¹.

H₈Si₈O₁₂ Exposure to Water-Modified Si(100)-2×1. Co-dosing experiments were performed with H₈Si₈O₁₂ clusters and water on Si(100). Figure 5a presents the RAIRS spectrum of a Si(100) surface exposed to a saturating dose of H₂O, typically 1–2 L (1 L = 1 × 10⁻⁶ Torr·s). In this spectrum, peaks are observed at 822 and 2086 cm⁻¹, corresponding to the ν(Si–OH) mode of surface hydroxide and ν(Si–H) mode of surface hydride, respectively, consistent with previous results.^{5,21} This modified surface was then immediately exposed to a saturating dose of H₈Si₈O₁₂, typically ~10 L. The IR spectrum of the new surface is shown in Figure 5b, and the difference of the

(15) Ehrley, W.; Butz, R.; Mantl, S. *Surf. Sci.* **1991**, *248*, 193.

(16) Agaskar, P. A. *Inorg. Chem.* **1991**, *30*, 2708.

(17) Bürgy, H.; Calzaferri, G. *Helv. Chim. Acta* **1990**, *73*, 968.

(18) Greeley, J. N.; Lee, S.; Banaszak Holl, M. M. *J. Appl. Organomet. Chem.* In press.

(19) Greeley, J. N.; Banaszak Holl, M. M. *Appl. Phys. Lett.* Manuscript in preparation.

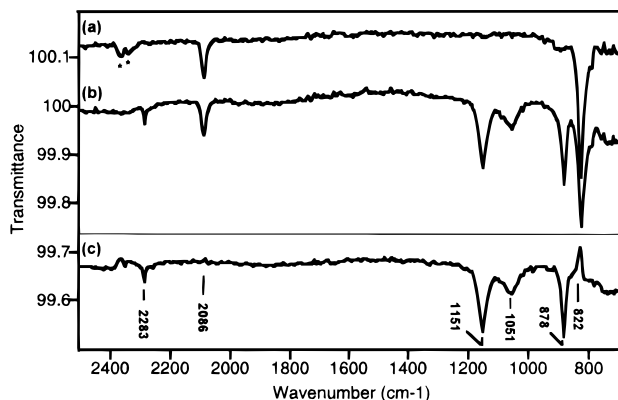

Figure 5. RAIRS spectra of (a) the H₂O-treated Si(100) surface, subsequently exposed to (b) H₈Si₈O₁₂. The difference, b-a, is plotted in part c. Peaks marked with an asterisk represent trace CO₂ in the purged optics bench.

Table 1. Experimentally Observed Vibrational Peaks (in Wavenumbers) and the Corresponding Assignments for the Cluster- and Water-Modified Surfaces^a

H ₈ Si ₈ O ₁₂ /Si Figure 4b	H ₂ O/Si Figure 5a	H ₈ Si ₈ O ₁₂ + H ₂ O/Si Figure 5b	[(CO) ₄ Co]H ₇ Si ₈ O ₁₂ Calzaferri et al. ²⁰	assign
2273		2283	2276	$\nu(\text{H}-\text{SiO}_3)$
	2086	2086		$\nu(\text{H}-\text{Si})$
1178		1151	1138	$\nu_a(\text{Si}-\text{O}-\text{Si})$
1101			1101	$\nu_a(\text{Si}-\text{O}-\text{Si})$
1058		1051		$\nu_a(\text{Si}-\text{O}-\text{Si})$
911			904	$\delta(\text{H}-\text{SiO}_3)$
889		878	886, 881	$\delta(\text{H}-\text{SiO}_3)$
859			857, 840	$\delta(\text{H}-\text{SiO}_3)$
	822	822		$\nu(\text{HO}-\text{Si})$
815				$\delta(\text{H}-\text{Si})$

^a The nomenclature is defined as the molecule to the left of the slash being used to modify the Si(100) surface.

two is seen in Figure 5c. New peaks are observed at 878, 1051, 1151, and 2283 cm⁻¹. The peak at ~822 cm⁻¹ exhibits a positive inflection, suggesting that a chemical reaction has caused a ~20% intensity attenuation of the $\nu(\text{Si}-\text{OH})$ mode, consistent with the observation of Eng *et al.*³ However, absolutely no change is observed in the $\nu(\text{Si}-\text{H})$ mode of the surface hydride at 2086 cm⁻¹. Area integration of the $\nu(\text{H}-\text{SiO}_3)$ mode at 2283 cm⁻¹ in spectrum 5(b) indicates that the cluster coverage is ~21% that obtained on a clean Si(100)-2×1 surface (Figure 4b). Two other features of note are the absence of any splitting in the $\delta(\text{H}-\text{SiO}_3)$ mode at 878 cm⁻¹ and the peak at 1051 cm⁻¹. For ease of comparison, observed peak frequencies in the different experimental systems are compiled in Table 1.

The reaction of H₈Si₈O₁₂ cluster with a water-covered surface was repeated with D₂O to initially modify the Si(100) surface. Figure 6a-c shows the spectra of the analogous deuterated experiments with similar exposures. In spectrum 6(a), peaks are observed at 837, 1516, and 2713 cm⁻¹, corresponding to the $\nu(\text{Si}-\text{OD})$ mode of surface deuterioxide, the $\nu(\text{Si}-\text{D})$ mode of surface deuteride, and $\nu(\text{SiO}-\text{D})$, respectively. A trace amount of $\nu(\text{Si}-\text{H})$ is observed at 2086 cm⁻¹ due to HOD present in the D₂O. The results are identical to those reported by Struck *et al.*,⁵ although we have been able to directly observe the $\nu(\text{SiO}-\text{D})$. As seen in the difference spectrum (Figure 6c),

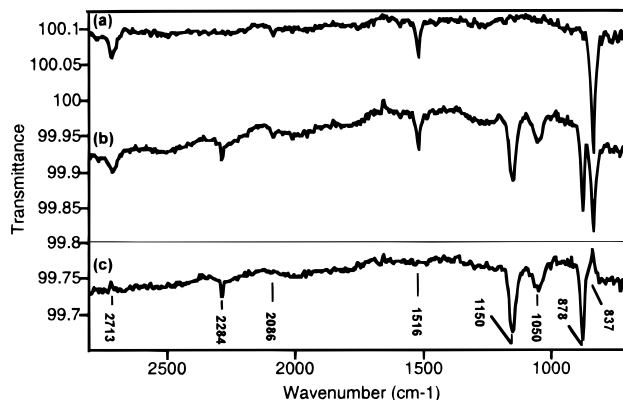

Figure 6. RAIRS spectra of the (a) D₂O-treated Si(100) surface, subsequently exposed to (b) H₈Si₈O₁₂. The difference, b-a, is plotted in part c.

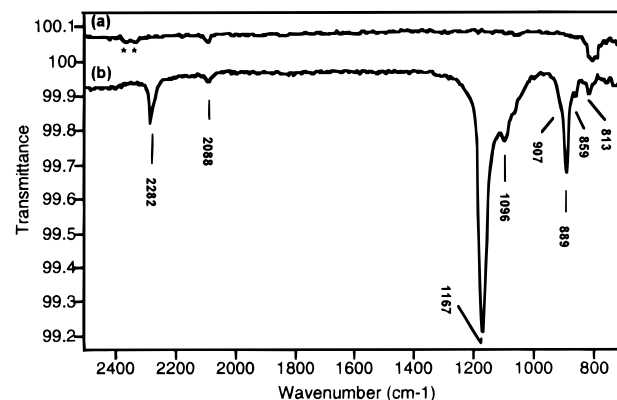

Figure 7. RAIRS spectra of (a) a 20% monolayer H₂O-treated Si(100) surface, subsequently exposed to (b) H₈Si₈O₁₂. Peaks marked with an asterisk represent trace CO₂ in the purged optics bench.

after exposure to a 10 L dose of H₈Si₈O₁₂ all of the qualitative features of the H₂O system are reproduced. The peaks at 837 and 2713 cm⁻¹ exhibit a ~25% decrease in intensity, there is no change in the $\nu(\text{Si}-\text{D})$ mode at 1516 cm⁻¹, the $\delta(\text{H}-\text{SiO}_3)$ mode at 878 cm⁻¹ is unsplit, and the peak at 1050 cm⁻¹ is present. The cluster coverage is ~17% that of a saturated surface.

For the sake of trying to mimic water-contaminated experimental conditions, H₈Si₈O₁₂ clusters were exposed to a Si(100) surface treated with submonolayer doses of water. Figure 7a depicts a Si(100) surface exposed to 0.05 L of H₂O, and exhibits the same features observed in Figure 5a. Figure 7b presents the result of exposing the water-modified surface to a saturating dose of H₈Si₈O₁₂. Spectrum 7(a) represents ~20% that of a saturated water-treated surface (correlating to ~10% Si-H surface coverage), while the cluster coverage in spectrum 7(b) is ~95% that of a saturated surface. Note that this spectrum is almost identical to Figure 4, with the exception of the additional peak at 2088 cm⁻¹ in spectrum 7(b). Finally, the $\delta(\text{H}-\text{SiO}_3)$ mode at 889 cm⁻¹ appears to be an intermediate mixture of spectra 5(b) and 4(b), suggesting that there is at least a partial interaction with surface hydroxyl groups. Nonetheless, it is clear that the dominate reaction is that of cluster with the clean Si(100) surface. The signal-to-noise was not sufficient to make a quantitative statement about the $\nu(\text{Si}-\text{OH})$ mode attenuation.

As a final check of this interaction, H₂O was exposed to a submonolayer coverage of H₈Si₈O₁₂-modified Si(100). Figure 8a shows the IR spectrum of a 2 L H₈Si₈O₁₂ exposure, giving a coverage of ~75% that of a saturated surface. This is

(20) Marcolli, C.; Calzaferri, G. *J. Appl. Organomet. Chem.* and references therein. In press.

(21) (a) Ibach, H.; Wagner, H.; Bruchmann, D. *Solid State Commun.* **1982**, *42*, 457. (b) Chabal, Y. J.; Christman, S. B. *Phys. Rev. B* **1984**, *29*, 6974.

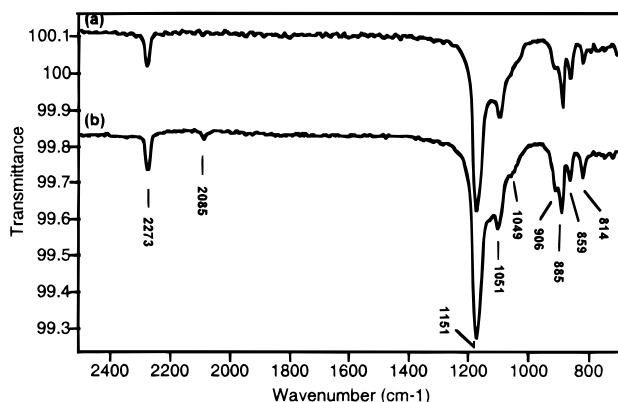

Figure 8. RAIRS spectra of (a) a 75% monolayer $\text{H}_8\text{Si}_8\text{O}_{12}$ -treated Si(100) surface, subsequently exposed to (b) H_2O .

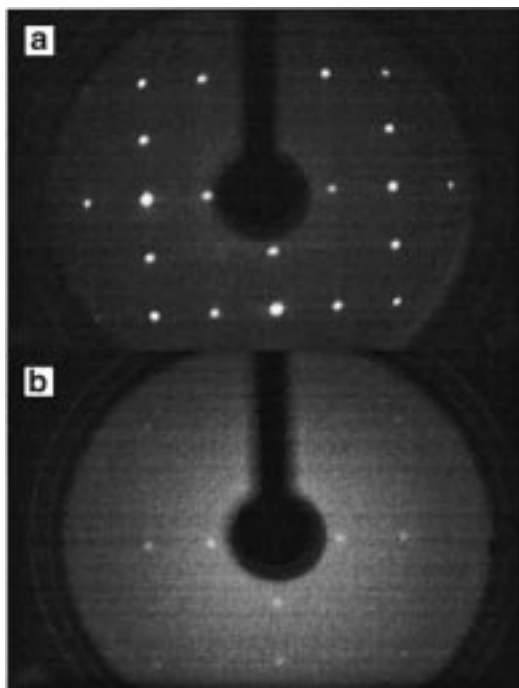

Figure 9. LEED pattern of (a) a clean Si(100)- 2×1 surface and (b) saturating exposure of $\text{H}_8\text{Si}_8\text{O}_{12}$ chemisorbed on Si(100).

juxtaposed with Figure 8b, where a subsequent saturating exposure of H_2O gives $\sim 35\%$ of a saturated water surface. Also note that the peak at 815 cm^{-1} has increased in intensity by at least a factor of 2, while the $\delta(\text{H}-\text{SiO}_3)$ modes have remained relatively unchanged. In all, these data demonstrate that the peak at $\sim 815\text{ cm}^{-1}$ is related to something other than water contamination when there is not a correlating peak observed at $\sim 2085\text{ cm}^{-1}$.

LEED of $\text{H}_8\text{Si}_8\text{O}_{12}$ Adsorbed on Si(100). To study the effect of the adsorbed cluster on the Si(100)- 2×1 reconstructed surface, a LEED study was undertaken. Figure 9a shows the LEED pattern of a clean Si(100) surface. Clearly seen are two (2×1) domains rotated by 90° to each other. Figure 9b presents the LEED pattern after clean Si(100) was exposed to 15 L of $\text{H}_8\text{Si}_8\text{O}_{12}$. Although quite diffuse, the half-order diffraction spots of the (2×1) phase are clearly visible, showing that the (2×1) order has not been destroyed. Because the (2×1) and (1×1) phases overlap, care must be taken to ensure that the pattern does not represent a mixture of different structures. However, the half-order spots have the same relative intensity as the whole-order consistent with only the (2×1) phase being

present. A (1×1) phase contribution would be manifested by an increased intensity in the whole-order spots.

It was also noted that the LEED pattern became completely diffuse over the course of a few minutes. This was not attributed to surface charging because the electron beam could be moved to a new position on the sample and the (2×1) structure would return. Most likely, this effect is the result of electron beam destruction of bound clusters to amorphous-like SiO_2 . A more detailed study of this decomposition mechanism is in progress.

IV. Discussion

The RAIRS data presented in this paper are consistent with an intact, chemisorbed cluster attached to the surface via one vertex. This assignment is consistent with numerous X-ray photoemission studies,^{2,6} as well as the initial work on this system, including theoretical calculations, performed by Eng *et al.*³ The structural assignment is also in excellent overall agreement with the solution IR spectra of analogous C_{3v} symmetric clusters. The key outstanding issues are the absence of a $\nu(\text{Si}-\text{H})$ mode at $\sim 2085\text{ cm}^{-1}$ and the presence of a $\delta(\text{Si}-\text{H})$ mode at 815 cm^{-1} . An issue related to the presence and/or absence of both of these modes, water contamination, will be addressed first.

Water Contamination at the $\text{H}_8\text{Si}_8\text{O}_{12}$ -Derived Si/SiO₂ Interface. The peak observed at $\sim 815\text{ cm}^{-1}$ is not present in the solution IR data for $\text{RH}_7\text{Si}_8\text{O}_{12}$ molecules,²⁰ and was not calculated to be present for the model molecule $\text{H}_7(\text{H}_3\text{Si})\text{Si}_8\text{O}_{12}$.³ Water-treated Si(100)- 2×1 surfaces have strong IR absorptions at ~ 820 and 2080 cm^{-1} , corresponding to $\nu(\text{Si}-\text{OH})$ and $\nu(\text{Si}-\text{H})$, respectively. On this basis, Eng *et al.* assigned the peak at $\sim 815\text{ cm}^{-1}$ as resulting from water contamination.³ Although no complementary Si-H feature was observed at 2080 cm^{-1} , it was thought that the absence could be explained by a lack of signal-to-noise, a dielectric screening attenuating the Si-H stretch, or a combination of the two. Unfortunately, dielectric screening mechanisms are complex and difficult to calculate a priori.²² Our approach for assignment of the $\sim 815\text{ cm}^{-1}$ peak has been 2-fold: exploitation of spectroscopic isotope shifts and co-dosing experiments that directly measure both Si-OH and Si-H vibrational features.

Chemisorbed deuterated-spherosiloxane clusters ($\text{D}_8\text{Si}_8\text{O}_{12}$) on clean Si(100)- 2×1 show no spectroscopic features between 700 and 1000 cm^{-1} (Figure 4a). The absence of the 815 cm^{-1} peak supports the assignment of this feature in Figure 4b as a $\delta(\text{Si}-\text{H})$ mode, not a Si-O stretching mode of any kind. Furthermore, based upon the series of co-dosed water/cluster spectra presented in this paper, it is inconsistent to assign the $\sim 815\text{ cm}^{-1}$ peak as $\nu(\text{Si}-\text{OH})$ without observing the conjugate partner, $\nu(\text{Si}-\text{H})$, at $\sim 2080\text{ cm}^{-1}$. Saturated, water-treated Si(100) surfaces subsequently exposed to clusters (Figures 5c and 6c) show an attenuation of the $\nu(\text{Si}-\text{OH}(\text{D}))$ mode, while leaving the $\nu(\text{Si}-\text{H}(\text{D}))$ mode unaffected. This clearly demonstrates that the cluster interacts solely with the $\nu(\text{Si}-\text{OH})$ mode in this system. When the submonolayer, water-treated Si(100) surface is exposed to clusters (Figure 7), the $\nu(\text{Si}-\text{H})$ stretch is still clearly observed. The presence of this peak shows that our experimental technique is sensitive enough to observe surface hydride concentrations of less than 1/10 of a monolayer in this system. The sum of these results demonstrates that the feature at 815 cm^{-1} does not arise from a water-derived Si-OH fragment, ruling out water contamination as a possible explanation for peak C in the photoelectron spectrum (Figure 1).

By demonstrating that water contamination is not present in these experiments and that the feature shifts as a function of

isotope labeling, the assignment of the $\sim 815\text{ cm}^{-1}$ peak (Figure 4b) must stem from the cluster. Although no feature is predicted in this region for a rigorously C_{3v} symmetric cluster, the actual symmetry of the cluster on the surface is lower. Normal mode calculations performed on models optimized at the AM1 level indicate that once the symmetry drops below C_{3v} , Si-H bending modes are expected in this region. Thus, the observed spectra remain consistent with an intact cluster being chemisorbed. The $\delta(\text{Si-H})$ modes are expected to be more sensitive to symmetry lowering than either the $\nu(\text{H-SiO}_3)$ or $\nu_a(\text{Si-O-Si})$ modes based upon both previous theoretical calculations and small molecule studies.^{3,4,20}

Another possible explanation for the 815 cm^{-1} mode is the presence of a surface Si-H moiety. Typically, $\delta(\text{Si-H})$ modes have not been observed for surface Si-H. In studies of silicon surfaces utilizing multiple-internal-reflectance (MIR) or attenuated-total-reflectance (ATR) techniques, no features below $\sim 1400\text{ cm}^{-1}$ have generally been reported.^{22,23} The studies utilizing BMLs to date appear to follow the same selection rules as RAIRS on metal surfaces.^{3,5,15} Since the $\delta(\text{Si-H})$ mode's primary projection is horizontal to the surface, this vibration is not typically detected, while the $\nu(\text{Si-H})$ is quite strong. However, in this case, the conjugate adsorbate, $\text{H}_7\text{Si}_7\text{O}_{12}$, is quite large, especially compared to the previously studied examples on BMLs: OH,⁵ OMe,¹⁵ and OEt.²⁴ If the cluster forces significant dimer asymmetry either by steric or electronic effects, the angle of the Si-H bond to the surface normal could deviate significantly from past cases. To the extent that this bond angle rotates away from the surface normal, the projection of $\nu(\text{Si-H})$ normal to the surface will decrease and the projection of $\delta(\text{Si-H})$ normal to the surface will increase. In principle, this effect can explain both the absence of an observed Si-H mode at $\sim 2080\text{ cm}^{-1}$ and the presence of an Si-H mode at 815 cm^{-1} . Additional studies are underway to further explore this issue.

Reaction of H₈Si₈O₁₂ with Water-Terminated Si(100).

Close examination of the $\delta(\text{H-SiO}_3)$ mode in Figures 4–8 shows dominantly one of two conditions: a single peak observed in Figures 5 and 6, or a split peak of three features as seen in Figures 4b, 7, and 8. These two conditions are reproducibly observed with clusters on water-treated and clean surfaces, respectively. While the split peak feature has been previously discussed as a breaking of degenerate modes induced by the lowering of symmetry, the single peak feature is more difficult to interpret. Namely, what is this cluster interaction that does not show the symmetry breaking features observed in analogous systems, yet still strongly binds to the surface at room temperature?

A second distinct effect has also been observed in the $\nu(\text{H-SiO}_3)$ region. Clusters on the water-treated surface exhibit an $\nu(\text{H-SiO}_3)$ stretch that is 10 cm^{-1} higher in frequency than clusters chemisorbed on a clean Si(100) surface (Table 1). Note that the modified Si(100) surfaces in Figures 5 and 6 have a common characteristic, some degree of oxidation. Considering this, two plausible binding modes can be offered. The first one involves Si-H bond activation of the cluster, in which the intact cluster would bind directly to a surface-bound oxygen (Figure 10a). In the case of clusters reacting with a water-treated Si(100) surface, the elimination of H₂ and the creation of a new Si-O-Si bond would result. This mechanism is consistent with the observed attenuation of the $\nu(\text{Si-OH(D)})$, and perseverance of the $\nu(\text{Si-H(D)})$, mode. It is also conceivable that the new

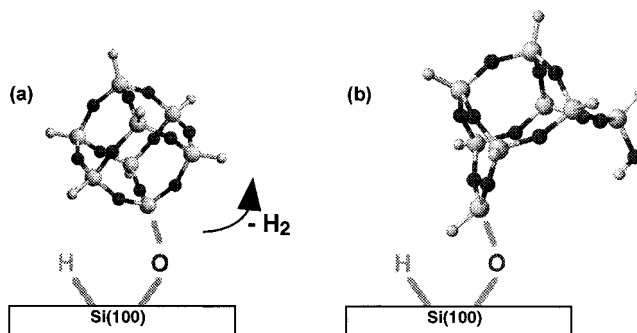

Figure 10. Schematic picture illustrating proposed reactions of H₈Si₈O₁₂ with a water-treated Si(100) surface.

Si-O-Si bond is the source of the $\sim 1050\text{ cm}^{-1}$ feature observed in Figures 5 and 6. AM1 level calculations suggest these modes should appear in this region. This type of model for bond formation, and the concomitant loss of H₂ gas, has been observed as a cross-linking mechanism for the related hydridosilsequioxane polymers.²⁵ This mechanism has also been invoked in the reaction of alkoxysilanes with amino alcohols,²⁶ which forms a product analogous to that shown in Figure 10a. Unfortunately, this model is unable to explain the lack of splitting in the $\delta(\text{H-SiO}_3)$ mode. The previously stated symmetry arguments should also be active here.

The second binding mode involves hydrolysis of a Si-O cluster bond by a surface Si-OH leading to a surface-to-cluster Si-O-Si bond and a cluster-based silanol (Figure 10b). Further reaction of the cluster silanol with the surface could result in a second surface-to-cluster Si-O-Si bond formation and the elimination of water. The presence of bands in the 1050 cm^{-1} region has been proposed as being indicative of ring-opening of the cluster compounds.²⁷ This model is also unable to explain the lack of splitting in the $\delta(\text{H-SiO}_3)$ mode. Both proposed binding modes have shortcomings; however, they still represent structures most consistent the data obtained to date.

Long-Range Surface Order. It is well-known that when the (100) face of crystalline silicon is cleaned *in vacuo*, a reconstruction of the surface results in rows of silicon dimers repeating a (2×1) lattice.^{28,29} While the chemisorption of most compounds occurs across adjoined silicon dimers, there are examples of reactions involving insertion into the dimer back-bond that result in surface reconstruction. Most notably, the exposure of atomic hydrogen to room temperature Si(100) is known to efficiently produce a dihydride terminated surface with a (1×1) phase.³⁰

As seen in Figure 9b, a diffuse (2×1) diffraction pattern is clearly visible. It is difficult to speculate what affect the H₈Si₈O₁₂ overlayer has upon the diffraction pattern, mainly because there are very few examples of LEED experiments involving such large adsorbates.³¹ However, because no new diffraction

(22) Chabal, Y. J. *Surf. Sci. Rep.* **1988**, 8, 211.

(23) For additional lead references on MIR and ATR experiments on surfaces containing Si-H see: Hattori, T. *Crit. Rev. Solid State Mater. Sci.* **1995**, 20, 339.

(24) Eng, J., Jr.; Raghavachari, K.; Struck, L. M.; Chabal, Y. J.; Bent, B. E.; Flynn, G. W.; Christman, S. B.; Chaban, E. E.; Williams, G. P.; Radermacher, K.; Mantl, S. *J. Chem. Phys.* **1997**, 106, 9889.

(25) Private communication with Udo Pernisz, Division of Electronic Materials, Dow Corning.

(26) Lukevits, E.; Simchenko, L. I.; Dzintara, M. *Zh. Obshch. Khim.* **1974**, 44, 1489.

(27) Brown, J. F.; Vogt, J. H.; Prescott, P. I. *J. Am. Chem. Soc.* **1964**, 86, 1120.

(28) Lander, J. J.; Morrison, J. *J. Chem. Phys.* **1962**, 37, 729.

(29) Ignatiev, A.; Jona, F.; Debe, M.; Johnson, D. E.; White, S. J.; Woodruff, D. P. *J. Phys. C* **1977**, 10, 1109.

(30) White, S. J.; Woodruff, D. P.; Holland, B. W.; Zimmer, R. S. *Surf. Sci.* **1978**, 74, 34.

(31) Carley, A. F.; Rajumon, M. K.; Roberts, M. W.; Wells, P. B. *Chem. Soc. Faraday Trans.* **1995**, 91, 2167.

spots are observed and the pattern becomes more diffuse, the adsorbate layer is presumed to only have a random scattering effect upon the electrons diffracting off of the (2×1) surface. Whether or not this offers insight into the long-range order of the adsorbate layer is unknown. Nonetheless, the clear retention of (2×1) phase diffraction spots is strong evidence that the chemisorption mechanism does not involve insertion into the Si dimers. This reinforces the notion that simple bond activation across a silicon dimer is the dominant chemisorption mechanism, as observed for many other molecules on Si(100).

V. Conclusions

RAIRS experiments were performed to explore structural and spectroscopic issues related to the model silicon/silicon oxide interface generated from $\text{H}_8\text{Si}_8\text{O}_{12}$ and Si(100)- 2×1 . The RAIRS data in this study are consistent with single vertex binding of the $\text{H}_7\text{Si}_8\text{O}_{12}$ cluster to the silicon surface in good agreement with previous spectroscopic studies of this system.^{2,3,6,9} Additional questions, in particular the issue of water contamination in the hydridosilsesquioxane cluster based model interfaces, were expressly addressed. These experiments demonstrate that no water contamination is detectable by RAIRS utilizing an experimental apparatus sensitive to less than 10% of a monolayer of silicon hydride on Si(100). Thus, the peak observed at a 1.0 eV shift from the bulk in the Si 2p core-level

spectrum of this model interface does not derive from water contamination (peak C, Figure 1). Conclusive evidence that adventitious water is not the origin of the 1.0 eV shift in the XPS spectra, in conjunction with IR data supporting the structural assignments made for the model silicon/silicon oxide interfaces, provides strong support for assigning Si 2p core-level spectra *with the explicit inclusion of the molecular or solid structure beyond the first neighbor coordination sphere*.⁹ The feature at 815 cm^{-1} , previously ascribed to a water-derived Si-OH mode, was shown via isotope labeling experiments to derive from cluster hydrogen. At this time, the experimental data do not allow a definitive assignment of the structural basis for this mode. Two reasonable assignment hypotheses are presented, $\delta(\text{Si-H})$ surface and $\delta(\text{H-SiO}_3)$ cluster. Binding modes resulting from cluster reactions with a water-modified Si(100) surface have also been proposed. Finally, it has been shown that the Si(100)- 2×1 surface reconstruction is maintained upon cluster chemisorption.

Acknowledgment. The authors thank J. Eng for extensive fruitful discussions regarding both experimental technique and data interpretation. This work was supported by the NSF (DMR-9727166) and Dow-Corning.

JA980741O